

Speed Level

UpRight

POWERED ACCESS



- Working height up to 11m
- Automatic platform levelling on slopes or uneven ground
- Rough terrain features include 4WD, oscillating front axle, high grip tyres
- 19°/35% gradeability
- Proportional drive/lift controls for smooth precise operation
- Diesel power

SL26SL
SL30SL

SL26/30SL speed level specifications

	SL26SL	SL30SL
max. working height A	10.0m	11.0m
max. platform height B	8.0m	9.0m
max. drive height	8.0m	9.0m
platform capacity (SWL)	680kg	590kg
platform size (inside guardrails)	1.72m x 3.86m	1.72m x 4.23m
platform size (with deck extended)	1.72m x 4.23m	n/a
stowed height C	2.6m	2.6m
stowed length D	3.79m	4.39m
width E	2.13m	2.13m
wheelbase F	2.54m	2.54m
height (guardrails folded)	1.1m	1.1m
gross weight	3,150kg	3,216kg
drive speed - max	5.0km/h	5.0km/h
with platform raised	0.8km/h	0.8km/h
gradeability	19° / 35%	19° / 35%
inside turning radius	3.9m	3.9m
axle ground clearance	200mm	200mm
chassis ground clearance	320mm	320mm
lift speed - raise/lower	21/32 sec	24/36 sec
drive system	four wheel with hydraulic motors	
platform levelling	13° to either side; 9° fore and aft	
tyres	26 x 12.00 - 12 NHS. Super Terra-Grip, poly-filled	
parking brake	spring-applied/hydraulically-released, multiple disc	
control system	proportional, joystick controller with thumb rocker steering. Automatic levelling control (inoperable above interlock height)	
power source	Perkins diesel, water cooled engine	

Specifications subject to change without notice. Photos and diagrams in this brochure are for promotional purposes only. Refer to appropriate UpRight operators manual for detailed instructions on the proper use and maintenance.



All models have oscillating axles to keep drive wheels in contact with uneven ground and have high levels of gradeability for tough sites and loading ramps.

BP1 SL26/30SL 10/06

standard features

- Diesel power
- Descent alarm
- Hour meter
- Speed level - automatic powered platform levelling
- Oscillating front axle
- Poly-filled high grip tyres
- Dual multi-disc brakes
- One-hand, proportional controls
- Wired for AC outlet on platform
- Fold-down guardrails
- 1 year parts and labour warranty
- 5 year structural warranty

options

- All motion alarm
- Flashing amber beacon and horn
- Diesel exhaust scrubber
- Special paint colours
- Environmental green oil

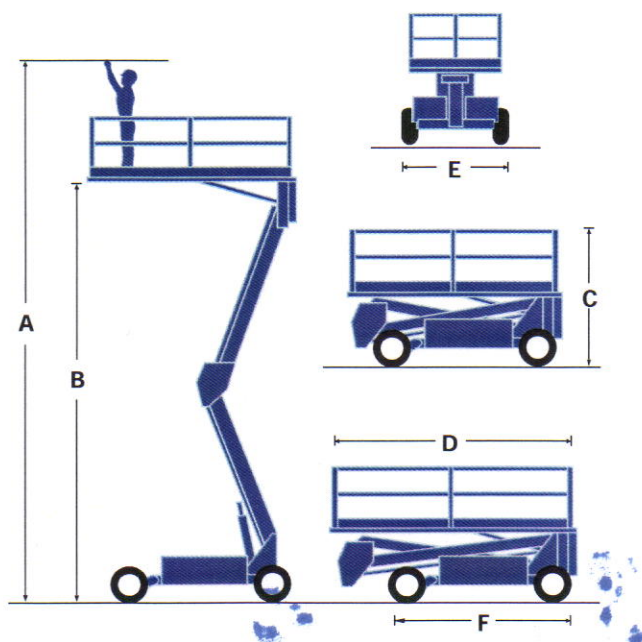

UpRight
POWERED ACCESS

Vigo Centre, Birtley Road, Washington,
Tyne & Wear, NE38 9DA, U.K.

Sales Tel: +44 (0) 845 1550 057 • Spare Parts Tel: +44 (0) 845 1550 058

www.upright.com

CE This product is available with the CE mark confirming compliance with all relevant European Machinery Directives

manufactured by
UpRight
POWERED ACCESS